



A Furukawa Company

■ **How do Fiber Optics Work?** | Fiber 101

Introduction

This section is written to provide an introductory look at how light travels over a span of fiber, and how this translates into a purchase selection. The information here, together with more succinct definitions found in the Glossary, is fundamental and will provide only the most basic level of understanding. Several textbooks have been written on the subject of fiber optics and their uses in various industries for different purposes. We recommend purchasing such a textbook for more indepth understanding. Also, our fiber-optic professionals here at OFS are available to offer advice and guidance in selecting the type, length, and other characteristics of bare or cabled fiber most suitable to your application.

Advantages of Fiber Optics

More Versatile. For over a century, copper wire has been used to conduct power, transfer data, and network machinery. However, copper has many limitations that have become more apparent and more troublesome as industries have found new data to gather, new conditions to sense, new environments in which to operate, new robotics to control, and so on.

Faster with more capacity. Optical fiber . . . in its many forms, cable configurations, and connectorizations . . . meets all these new needs with plenty of room to grow for the future. Glass optical fiber has greater bandwidth and faster data rates. Ounce for ounce, meter for meter, dollar for dollar, millisecond for millisecond, fiber can carry more data, faster than copper. Compared to copper-based systems, fiber has many advantages, and some applications would actually be impossible without it. Fiber optic cables are easier to install, require less duct space, and weigh approximately 13 times less than metal cables.

EMI/RFI immunity. Glass optical fibers do not emit any radio or electromagnetic waves or radiation to interfere with other non-optical components in the vicinity. Fiber is immune to electromagnetic and radio frequency interference (EMI/RFI) as well as voltage fluctuations and requires no ground-loop insulation. As a basic example, EMI results in the static you would see on your television set if you were to run a vacuum cleaner in proximity to it. Power surges or brownouts also have no effect on the optical transmission of data over optical fibers or cables (although electronic components on either end of the transmission fiber may still be affected.)

Reduced loss. In any system where you are transporting one item from an originating location to a receiving location, there will be some loss en route — from a variety of causes. In the case of data transmission, this loss is usually referred to as “attenuation.”

Transmission of data by means of light waves rather than by electricity over copper or other metallic media drastically reduces the amount of loss over all but the very shortest lengths, allowing for longer cable runs and fewer repeaters (or re-transmitters) along the route.

More durable. Fiber — with the addition of specialty coatings — can be made far more durable than traditional, outdated copper cabling or other glass or plastic fibers available as commodities from other manufacturers. Certain coatings can be used to take fiber to new highs in temperature, allowing glass fiber to withstand temperatures up to 400°C for short durations.

More flexible. Fiber can be designed to squeeze around tight corners and withstand outerspace and oceanic environments while continuing to transmit data flawlessly where other transmission media would be unreliable or fail.

Fiber Optic Basics

Fibers come in four main configurations, each suited ideally to a different usage: single-mode, polarization-maintaining single-mode, multimode step-index, multimode graded-index. The differences among them relate mainly to the range of wavelengths at which the light will be transmitted/received, and the total amount of information that needs to be transmitted at any one time (referred to as “bandwidth”).

Single-mode. Fibers have a small core size ($<10\ \mu\text{m}$) which permits only one mode of light to be transmitted. Because only one mode of light is supported, pulses (each carrying information in the form of light at the single mode), can be transmitted more frequently over the length of the fiber. As a result, bandwidth is higher in single-mode fiber than in multimode.



Single-Mode Fiber

Polarization-Maintaining Single-mode.

Polarization-Maintaining (PM) fiber is a special type of single-mode fiber; the fundamental mode has two perpendicular components.

PM fibers are designed with asymmetrical stress applied along one axis. This squeezes the fiber core, creating two perpendicular axes, each having a different index of refraction and therefore a different propagation speed. When polarized light is launched into one of the axes, almost no crosstalk occurs with the other axis, and the polarization is maintained. If polarized light were to be launched into a regular single-mode fiber, the polarization would deteriorate over its length. PM fibers have increasing use in the components that make up coherent telecommunication systems.

Multimode Introduction. Fibers have larger cores which guide many modes simultaneously. When one pulse of a signal is generated into a multimode fiber, the multiple modes enter the fiber core from different angles and each mode propagates at a different speed. This causes pulse broadening (modal dispersion), and limits the speed at which subsequent pulses may be generated without overlapping.

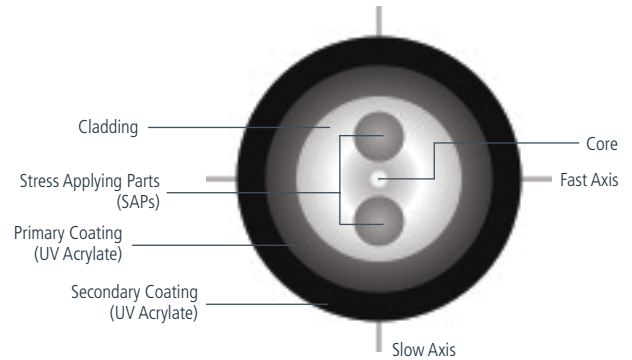

Multimode Step-Index. Fibers carry multiple wavelengths of light in a uniform refractive index core. The cladding serves as a type of full-length mirror, reflecting the light in straight paths at angles back to the other interior wall of the core and so on down the length of the fiber. Each mode of light is launched at one end and travels through to the other end at a unique angle, allowing for the receiver to sort the modes and decode them based on their angle of receipt.

Multimode Graded-Index. Fibers were designed to limit the amount of modal dispersion. The index of refraction of the core changes gradually from the center point outward. This causes the velocity of the modes to increase as they travel away from the core. This equalizes the time it takes the multiple modes to travel down the fiber to reduce modal dispersion and increase bandwidth.



Multimode Step-Index Fiber

Basic Fiber Mechanics

Fiber uses a layering construction in concentric circles for both optical and mechanical advantages. A “core” of silica glass, sometimes treated (or “doped”) with another element to change its refractive index, is completely surrounded by a “cladding,” which acts as a guide to the light waves, preventing light from leaking out of the core and keeping it traveling in the proper direction down the length of the fiber to its destination.

Surrounding the cladding is usually another layer, called a “coating.” This layer is purely mechanical in nature, serving different functions such as providing handling protection and corrosion resistance. The term “coating” usually refers to protective layers (polymer or carbon) that are applied during the fiber drawing process, before the fiber contacts any surface. “Buffers” are further protective layers applied on top of the coatings.

When additional jacketing layers are applied to a fiber on an extrusion line, the result is usually considered “cable.” Cable has more rugged properties, such as crush resistance and increased resistance to temperature fluctuations and pulling forces. Many fibers can be sealed together into a single length of cable using a variety of jacketing materials, strengthening members, and protective elements.

To allow a fiber or cable to do its ultimate job of transmitting information, it eventually must be connectorized. A connector is affixed to one or both ends of the fiber or cable using either a “crimp and cleave” process or an “epoxy/polish” method, depending on the type of fiber or cable and its application. Connectors are available from OFS or separately in many varieties to match industry standards and protocols.

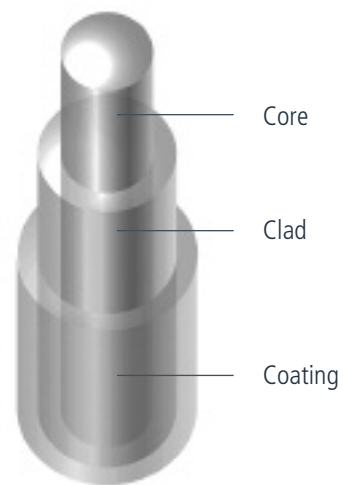

Fiber Construction